

FAA Workshop on Adhesive Bonding

Ch. KAUFFMANN Head of Technology Department



- **Company and Products presentation**
- **Presentation of typical sandwich structures**
- **Design criteria**
- **Materials used in bonded structures**
- **Materials qualification**
- **Justification of bonded structures**
 - Bonding validation
 - Damage tolerance (manufacturing and in-service defects)
- **Stress substantiation**
- **Manufacturing process control**

Hurel-Hispano Company overview

- HH masters the expertise for design, development and manufacture of a wide range of engine nacelles that are used by leading aircraft manufacturers and airlines worldwide.
- Annual turnover 615M€ in year 2003



2,600 employees in Europe

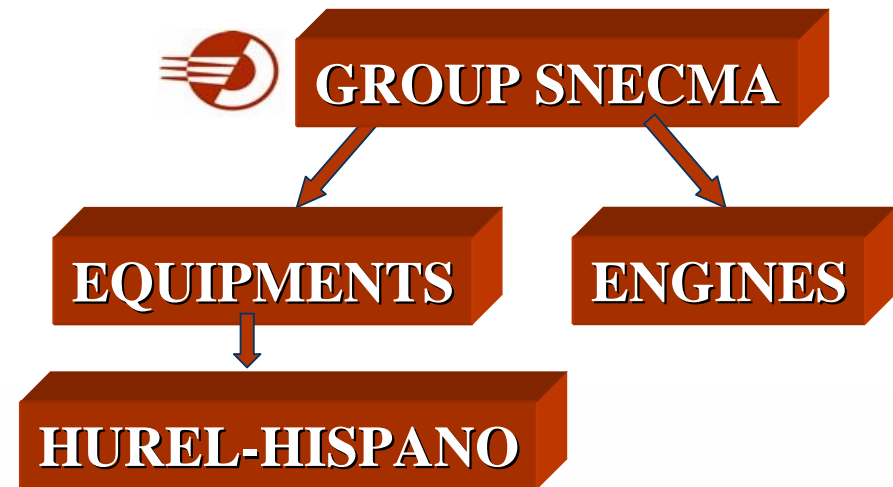

► Nacelle components

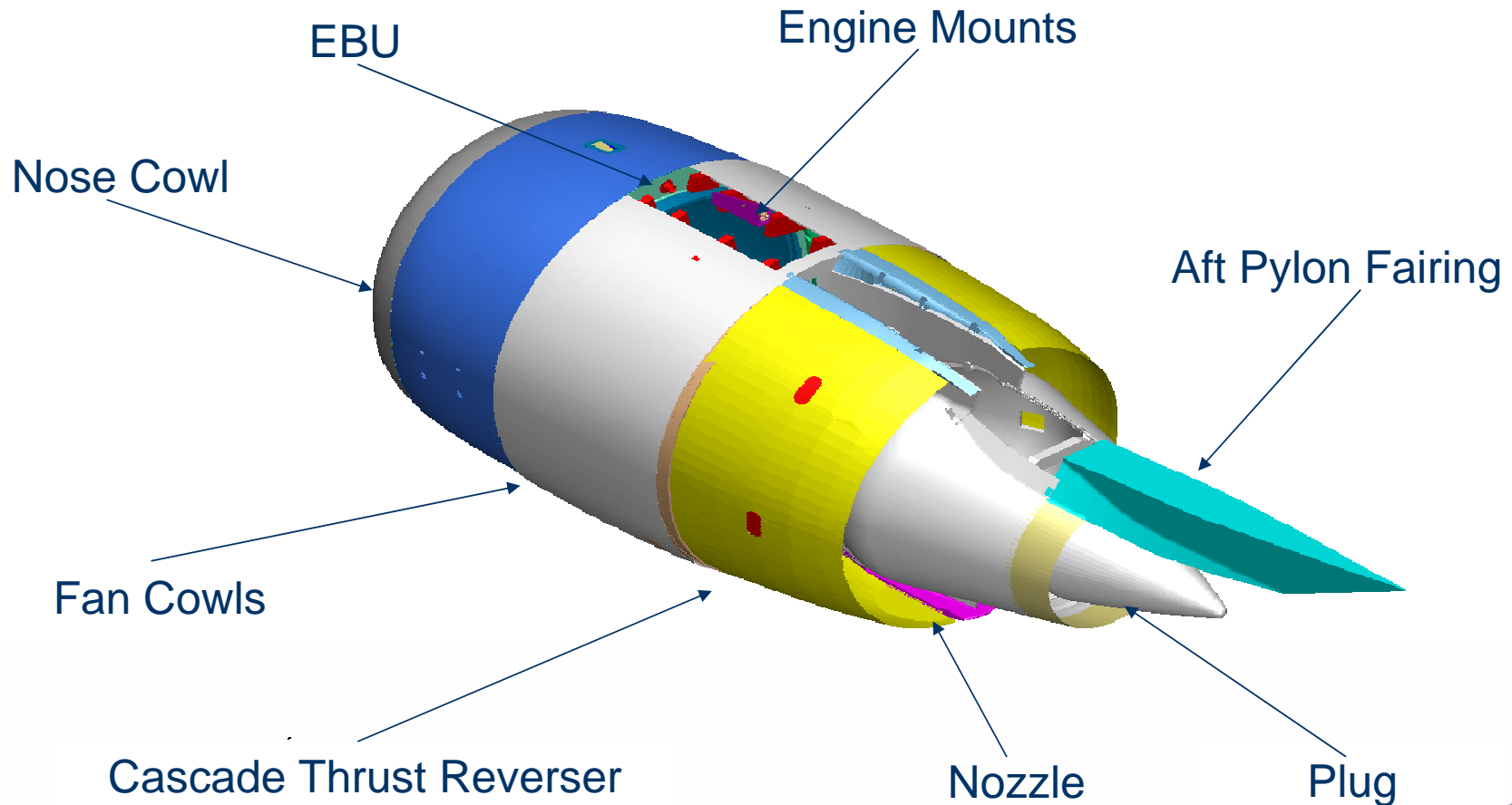

▶ Examples of thrust reverser technology



**Cascade
Trent 500**



**Pivoting Door
Trent 700**



**Pivoting Door
CFM 56**



**2 Door
Target
BR710**



**PERT[®]
AS907**



**'Natural' Cascade
CF34-8**

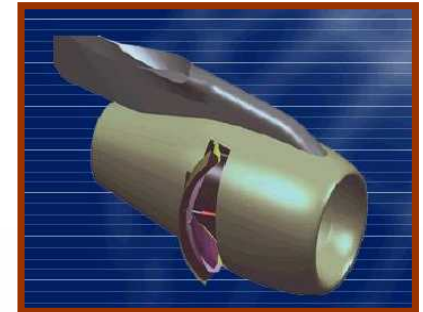

**Papillon[®]
PW6000**

Hurel-Hispano programmes presentation

▶ Large aircraft division products

Airbus programmes



A380 with RR Trent 900 and GP7200 - Nacelles
A340-500/600 with RR Trent - Nacelle
A340-200/300 with CFM56 - Thrust Reverser
A330 with RR Trent 700 - Thrust Reverser
A320 with CFM56 - Thrust Reverser
A318 with PW6000 - Nacelle

Boeing programmes



Boeing 747 with RR RB211 - Thrust Reverser
Boeing 767 with RR RB211 - Thrust Reverser

Presentation of sandwich structures

The nacelle components form the fan air cowling of the engine.

In that respect, they must ensure the required aerodynamic shape of the fan duct an outer surface.

The cowling surface is made of sandwich panels that must fulfill structural requirements as well as other requirements such as acoustic attenuation and fire protection.

The design of these sandwich panels must take into account the above requirements together with a strong incentive to minimise weight.

Hurel-Hispano make extensive use of adhesive bonding technology in the design and fabrication of honeycomb sandwich panels.

≡ Presentation of sandwich structures

▶ 2 types of sandwich structures :

- metallic sandwich structures

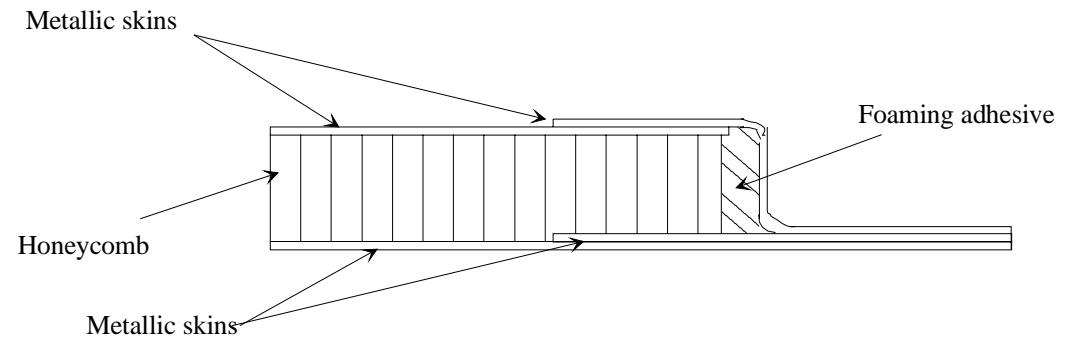
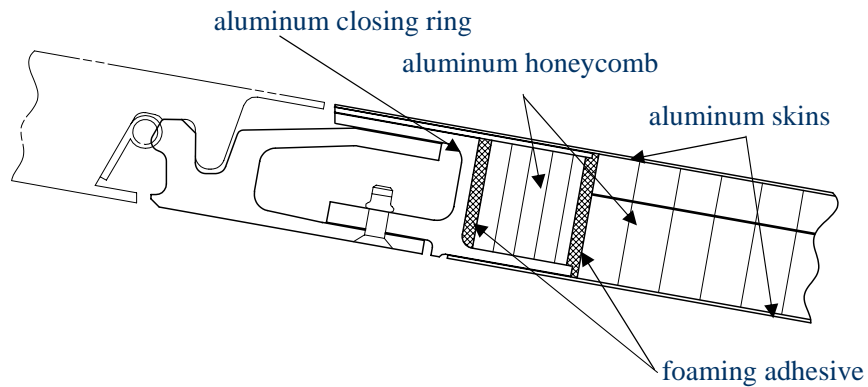

- composite sandwich structures

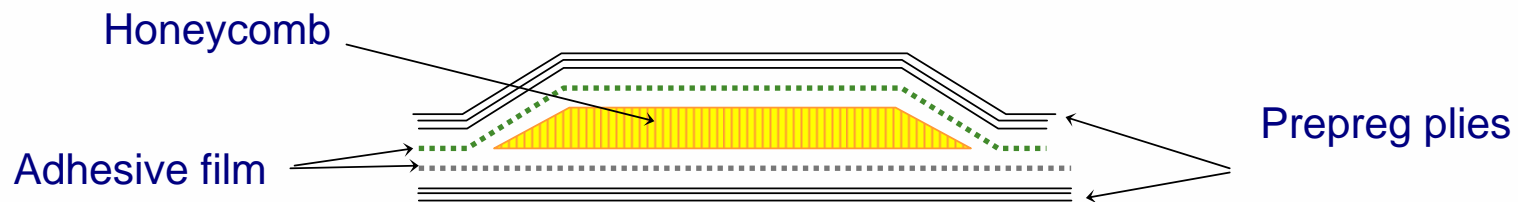

▶ Examples of sandwich structures

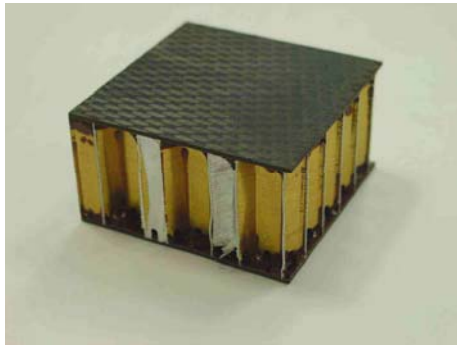

Composite sandwich with aluminium honeycomb

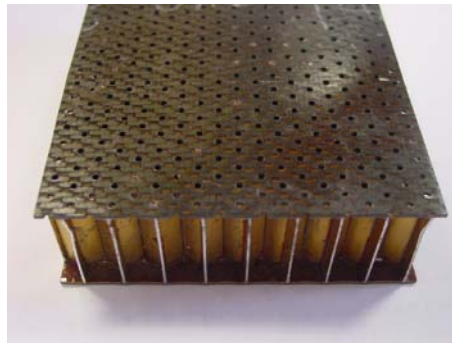

Composite acoustic sandwich with aluminium honeycomb

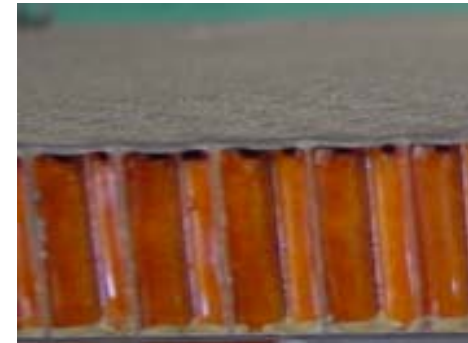

Composite sandwich with Nomex honeycomb

Design criteria

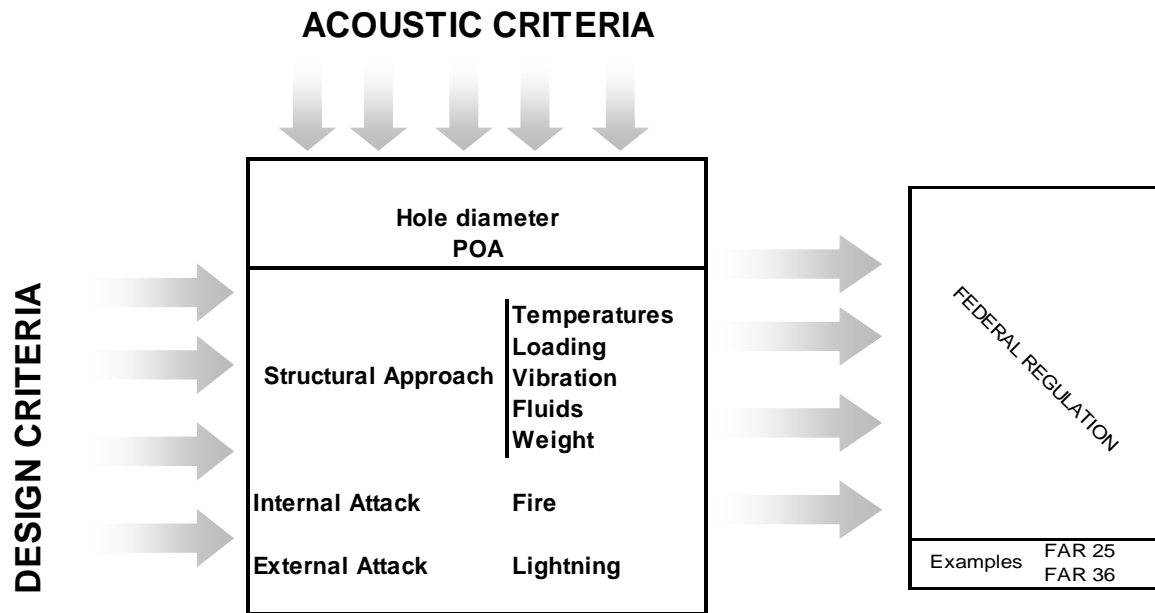

SDOF : Single Degree of Freedom

2DOF : 2 Degrees of Freedom

LINEAR : With Wire Mesh

POA : Percentage of Open Area

FAR25 : Airworthiness Standards

FAR36 : Noise Standards

Design constraint and environmental conditions :

Structural capability (static, fatigue, vibration)

Minimum weight

Aerodynamic shape and smoothness

Limited size

Fluids drainage (moisture, fuel)

Damage tolerance

Engine environment (temperature)

Life hours and cycles

Noise level requirements

- **Metallic sandwich**

- Aluminium skin : CAA treated with bonding primer
- Structural adhesive film (reticulated on air washed skin)
- Aluminium honeycomb : cell size from 1/8" (non acoustic) to 3/8" (acoustic), density : from 3.0 to 22.1 pcf)

- **Composite sandwich**

- Epoxy or BMI carbon prepregs
- Epoxy or BMI glass prepregs (for galvanic corrosion protection)
- Epoxy or BMI structural adhesive films
- Aluminium or Nomex honeycomb (cell size and density identical to metallic sandwich)

- **Material selection**

- Service temperature is the driving factor for material selection : Epoxy for service temperature below 120°C and BMI for temperature below 170°C.

Materials qualification : static.

- **In accordance with the requirements of the JAR 25.603 and 25.613**
- **Each material validated on several batches : 3 to 5 batches and B value determination according to the MIL-HANDBOOK 17**
- **Taking into account of environmental conditions**
 - Tests in temperature (from -55°C to in max service temperature)
 - Tests after ageing : wet ageing, thermal ageing, wet + thermal ageing
 - Tests after thermal cycling
 - Tests after immersion in hydraulic fluids
 - Tests after salt spray
- **Standard test : physico-chemical and mechanical tests**
 - ➔ Determination of design values (B-values) for each material

Design justification : bonding validation.

- **Typical standard tests**
 - Flatwise tensile tests
 - Climbing drum peel
 - Shear strength by 3-points bending test
 - Hot wet testing
- **Typicaly one batch of material tested. Some programmes have required 3 batches of adhesive film.**
- **Cut out of component for manufacturing process validation.**

≡ Design justification : Damage tolerance

- **JAR 25-603 and ACJ 25-603**
- **Manufacturing defects and in-service damages**
 - Fatigue tests on impacted specimens and specimen with typical manufacturing defects to demonstrate the no-growth under fatigue loading
 - Specimen loading : compression or tension in the skins
 - Determination of the residual strength
- **Damage tolerance design allowables**
 - 3 batches tested (typical)
 - B value determination using MLHDBK17.
- **Fatigue conditions**
 - from 20 000 cycles to 80 000 cycles depending on the A/C design life.
 - criteria of fatigue cycling of composite specimen :
 - ▼ Design fatigue loads with a load enhancement factor of 1.15, associated with 1.5 aircraft life or :
 - ▼ Design fatigue loads with a load enhancement factor of 1.17, associated with 1 aircraft life.

- **Component Modelling**
 - Use of a correlated (loads and loads paths defined) finite element model
- **Comparison between the FEM datas and the design allowables**
 - For ultimate loads
 - ▼ microstrains in the skins are compared to material damage tolerance allowable microstrains
 - ▼ shear stress at interface between skin and honeycomb are compared to shear stress allowables
 - Check that fatigue loads from FEM are covered by fatigue tests on damage tolerance material allowables.
- **Determination of safety margins**
- **Sub component testing**
 - Used for damage tolerance substantiation of specific areas like advanced design areas or certain load introduction areas
- **Component testing**
 - Used mainly for FEM correlation
 - Instrumentation during engine test

- **Non destructive inspection on parts (C-Scan, A-Scan)**
- **Manufacturing followers tests**
 - Standard tests : flatwise tension, climbing drum peel, single lap shear
 - Same configuration as the component (material, manufacturing process)
 - Specimen definition : Use of standard test specimen to be able to correlate with qualification data base and to define consistent pass/fail criteria.

Thank you for your attention

